



BANBROS ENGINEERING PVT. LTD.

The Precision Measurement People

STEEL BAR BENDING & REBENDING TESTING MACHINE



- **VALUE**
- **VERSATILITY**
- **PERFORMANCE**

BBBM-40C

**DESCRIPTION:**

Bending steel testing machine is a device for cold bending tests and surface root bending tests on steel.

This steel bending testing machine features compact structure, easy operation, large carrying capacity, smooth running, low noise, clear display of the bending angle and easy maintenance, to name just a few. It is an ideal device for steel plants and quality inspection units to test the bending and anti-bending performance of hot-rolled ribbed steel bars. It's conformed with ASTM A615 , ISO 15630, AS/NZS 4671 and EN 10080 standard.

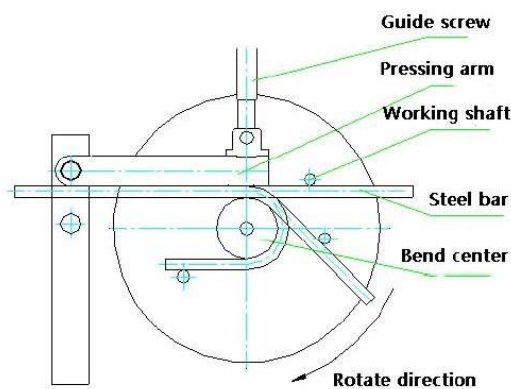
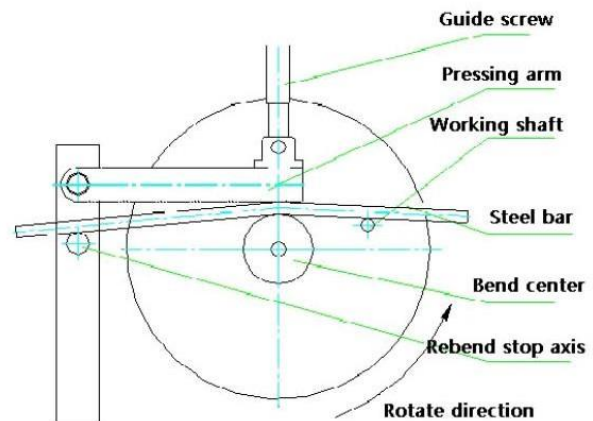
Motorized forward bending test**Motorized reverse bending test****TECHNICAL SPECIFICATION:**

Model	BBBM-40C
Bending test steel bar diameter	φ6~φ40mm
Forward bending angle	0°-180° free setting
Reverse bending angle	0°-90° free setting
Rotating speed of working plate	1.4 r/min
Working table size	φ860mm
Roller center distance	280mm
Motor power	3 Kw
Steel bar bending center standard accessories HRB400 HRBF400	4×φ6, 4×φ8, 4×φ10, 4×φ12, 4×φ14, 4×φ16, 4×φ18, 4×φ20, 4×φ22, 4×φ25, 5×φ28, 5×φ32, 5×φ36, 5×φ40, 6×φ50 A total set of fifteen pcs
Working roll	Φ52, Φ68 each one
Bending mandrel	Φ56
Power supply	380V, 50HZ, 3phase
Dimension	1050×750×1200mm
Weight	800Kg
Power	3kw

**OPTIONAL BENDING CENTER:**

Description	Set
Can complete the bending performance test of steel bars (180°) HRB500 HRBF500	6×Φ6, 6×Φ8, 6×Φ10, 6×Φ12, 6×Φ14, 6×Φ16, 6×Φ18, 6×Φ20, 6×Φ22, 6×Φ25, 7×Φ28, 7×Φ32, 7×Φ36, 7×Φ40, 8×Φ50 A total set of fifteen pcs
Can complete the bending performance test of steel bars (180°) HRB600 HRBF600	6×Φ6, 6×Φ8, 6×Φ10, 6×Φ12, 6×Φ14, 6×Φ16, 6×Φ18, 6×Φ20, 6×Φ22, 6×Φ25, 7×Φ28, 7×Φ32, 7×Φ36, 7×Φ40, 8×Φ50 A total set of fifteen pcs
If the steel bar reverse bending performance test needs to be completed Order separately (positive bend 90°, reverse bend 20°) HRB400E HRBF400E	5×Φ6, 5×Φ8, 5×Φ10, 5×Φ12, 5×Φ14, 5×Φ16, 5×Φ18, 5×Φ20, 5×Φ22, 5×Φ25, 6×Φ28, 6×Φ32, 6×Φ36, 6×Φ40, 7×Φ50 A total set of fifteen pcs
If the steel bar reverse bending performance test needs to be completed Order separately (positive bend 90°, reverse bend 20°) HRB500E HRBF500E	7×Φ6, 7×Φ8, 7×Φ10, 7×Φ12, 7×Φ14, 7×Φ16, 7×Φ18, 7×Φ20, 7×Φ22, 7×Φ25, 8×Φ28, 8×Φ32, 8×Φ36, 8×Φ40, 9×Φ50 A total set of fifteen pcs

